



Step 1
Hold the snappy ladder in vertical position.



Step 2
Expand the sides of snappy ladder horizontally for free standing of ladder. Fit platform in position.



Step 3
Expand both the stabilizers horizontally for increasing stability.



Step 4
Close the guardrail gate by moving down for safe working.

SNAPPY

A practical single - sided mobile ladder that can be used anywhere.

FEATURES :

- Ladder width 52cm, rung gap 28cm with guardrail height 96 cm.
- 2 fixed castor wheels.
- Spacious platform : 41.0 cm x 62.0 cm
- Platform railing with intermediate & toe board.
- Maximum load capacity : 150kg
 - *Read Safety Instruction for Safer usage.*
 - *Designed as per EN131 Standard.*



SPECIFICATION			SNAPPY			
LENGTH	WIDTH	OVERALL HEIGHT	PLATFORM HEIGHT	NO OF STEPS	WEIGHT	WEIGHT WITH WHEEL
134 CM	52 CM	190 CM	100 CM	3	13.0 Kg	15.4 Kg
190 CM	52 CM	240 CM	150 CM	5	21.5 Kg	23.9 Kg
214 CM	52 CM	290 CM	200 CM	6	24.5 Kg	26.9 Kg

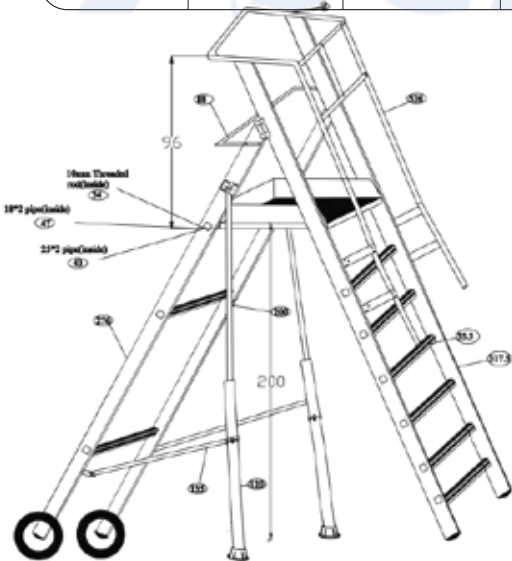

“SNAPPY” INSTRUCTION MANUAL

ALWAYS READ THE INSTRUCTION MANUAL FOR SAFER ASSEMBLY OF SNAPPY



PASMA(UK)APPROVED TRAINING CENTER

ASCEND ACCESS SYSTEMS SCAFFOLDING L.L.C.

Tel : +971 4 885 5001
 Toll Free : 800 722 33653
 Email : sales@ascenduae.com
 Website : www.ascenduae.com

SNAPPY

A practical single - sided mobile ladder

Ladders – Proper Set Up

1. DANGER! Metal Conducts Electricity! Do not let ladders of any material come in contact with live electrical wires.
2. Make sure ladder is fully open, spreaders secure, and pail shelf in position.
3. Place on firm level surface with a secure footing. Do not use on slippery surfaces. Do not place on boxes, unstable bases or scaffolds to gain additional height. Do not place in front of door opening towards ladder.

Ladders – Proper Climbing & Use

1. Face ladder when climbing up or down, keep body centered between side rails.
2. Maintain a firm grip. Use both hands in climbing.
3. Never climb a ladder from the side unless ladder is secure against side wise motion, nor climb from one ladder to another.
4. Do not walk or jog ladder when standing on it.
5. Do not stand, climb or sit on ladder top, pail shelf, braces, or back section.
6. Do not overload, ladder is meant for one person.
7. Keep ladder close to work, avoid pushing or pulling off the side of ladders.
8. Clutter around the base of the ladder should be removed from the working area by setting up traffic barrier.
9. Block off the area of work.
10. Only one person at a time should climb a ladder.
11. Maintain a 3 point contact with ladder.
12. Never leave a ladder set up unattended.
13. Never allow children to climb a ladder.
14. Keep shoes clean, leather soles should not be worn.

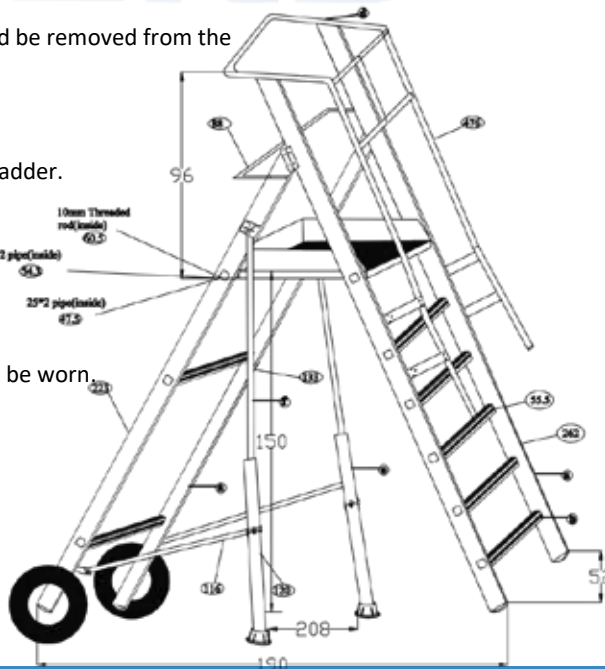

SNAPPY

A practical single - sided mobile ladder

General Ladder Safety

If ladder is used properly and according to safety guidelines, it will give many years of trouble free service. However, if proper cautions are not taken, a ladder can be involved in an accident. Please read and follow all instructions and labels accompanying each ladder.

Two factors that deserve particular attention are proper ladder selection and electrical shock precautions:

Pay close attention to the Duty Rating of the ladder and the combined weight of the user and materials.

Be aware of wires, electrical devices and live electrical circuits. Metal ladders conduct electricity and can create a danger of electrocution. Failure to read and follow instructions regarding electrical safety could result in serious personal injury or death.

Inspection Before Each Use

1. Inspect upon receipt and before each use. Never climb a damaged, bent or broken ladder, all working parts must be in good working order.
2. Make sure all rivets and joints, nuts and bolts are tight; feet, steps and rungs are secure; spreaders and pail shelf function properly (on step ladders);
3. If you are in poor health, subject to fainting spells, have physical handicap that would impair your climbing ability, or if you are under the influence of any drugs or alcohol (including legal drugs that may cause drowsiness), you should not use a ladder.
4. Do not use in high winds or during a storm.
5. Stay focused on safety whenever you are on the ladder, and keep your body weight between the rails.

Proper Care & Storage of Ladders

1. Store ladders in a safe, dry place.
2. Properly secure and support ladders while in transit.
3. Keep ladders clean and free of foreign materials.
4. Never store materials on ladders.
5. Regularly clean and lubricate the ladder's moving parts. Clean the rungs and steps.